

This hole is for AT-Disengage button. Redimension hole to fit your button.

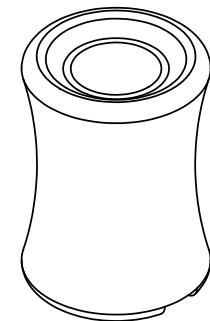
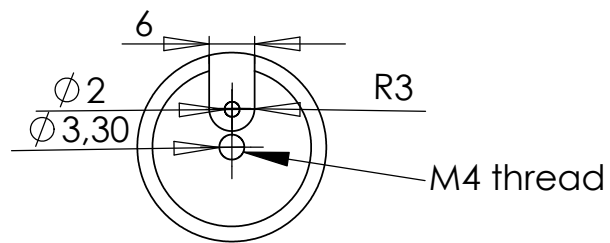
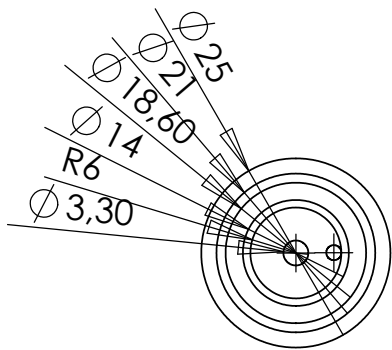
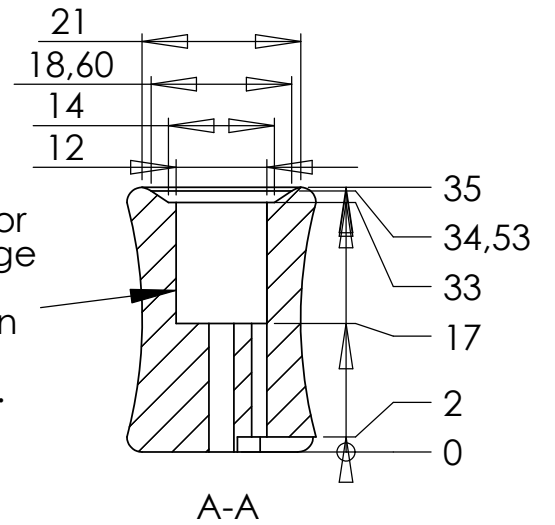

TITLE:		ThrottleKnob	
A4	Copyright 2003 Jari Mikkilä		
DO NOT SCALE DRAWING	Date:		
SCALE:1:1	MATERIAL:		